

Harness Structural test Report

Inspection certificate number: **PH_289.2019**

Manufacturer data:

Manufacturer name: **Supair Sàrl**
 Representative: **Laurent Chiabaut**
 Street: **34, rue Adrastée**
 Post code place: **74650 Chavanod**
 Country: **France**

Sample data:

Name: **T_Line**
 Type: **ABS**
 Size: **L**
 Serial number: **TYR-L-V7.2**
 Impact pad type: ⁽¹⁾ **n/a**
 Clip-in weight [kg]: **130**

Date of test: **06.11.2019**

Atmosphere AGL:

[C°]	23
RH [%]	51
[hPa]	962.5

Summary of Structural test

Test id	- EN 1651:2018	Setup	Req. Load		Min. duration [s]	Result
			[g]	Req. Load [N]		
01 ⁽³⁾	✓ 5.5.1.1	Positive symmetric load (Slippage)	4.5	5850	5	POSITIVE
03 ⁽³⁾	✓ 5.5.1.1b	Positive symmetric load	15	19500	5	POSITIVE
05	✓ 5.5.1.2	Positive asymmetric load	6	7800	5	POSITIVE
09 ⁽³⁾⁽⁴⁾	5.5.1.3	Positive symmetric load rescue points	15	19500	5	n/a
10 ⁽³⁾⁽⁴⁾	5.5.1.4	Negative symmetric load rescue points	15	19500	5	n/a
14	✓ 5.5.1.5	Negative symmetric load towing points	5	6500	5	POSITIVE
06	✓ 5.5.1.6	Negative symmetric load	6	7800	5	POSITIVE
12 ⁽³⁾	✓ 5.5.1.7	Upright (landing) position load	6	7800	5	POSITIVE
11	5.5.1.8	Connecting element for rescue	n/a	24000	0.3	n/a
08 ⁽⁵⁾	5.5.1.9	Anti falling-out system	4.5	5850	5	n/a

Rescue deployment test

Test id	- NfL II 91/09	Setup	Min load		Measured [N]	Result
			[N]	Max. load [N]		
RRDT	6.1.5	Default flying position	20	70	0.00	n/a

Rescue Deployment Handle strength test

Test id	- EN 12491	Setup	Req. Load [N]	Min. duration [s]	Breaking strength [N]	Result
RRST	5.3.2	Two end points of handle	700	10	0.00	n/a

Manufacture	Instrument	Type no	S/N	Validity Calibration
HBM	Load Sensor GE01	1-S9M/50KN-	31314643	04.09.2023
Burster	Sensor Burster	8431-10000	1185483	04.09.2023
JDC elec	Geos n°11 Skywatch	Geos n°11	22	08.05.2020

The validation of this test report is given by the signature of the test manager on the Inspection Certificate no 94.20

(1) If Impact pad available, see test report no. 94.22 and inspection certificate no. 94.20. ⁽³⁾ Slipping test of any adjustable components: No slippage of any adjustable element more than 10 mm at 4500N for 5 s. The marks should be added with a pre-load of 1000N. ⁽⁴⁾ For harness with integrated Y bridle, test in the end loop ⁽⁵⁾ Attach to anti-falling out system without connecting the crotch straps (breast straps)

Calculated value in tests reports include the value minus the uncertainty (on safe side) / The uncertainty stated is the expanded uncertainty obtained by multiplying the standard uncertainty by the coverage factor k = 2. The value of the measurand lies within the assigned range of values with a probability of 95%.

This declaration must not be reproduced in part without the written permission of AIR TURQUOISE SA.

Inspection certificate number: **PH_289.2019**

model: **T_Line**

Harness Structural test

Test ID 01

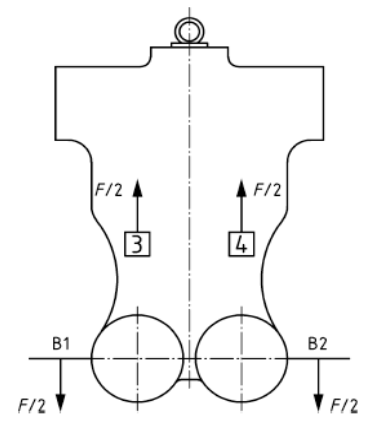
Standard	EN 1651:2018	
Reference in standard	5.5.1.1	
Test setup	Positive symmetric load (Slippage)	
Attachment points	Both main riser attachment (3,4)	
Anchor points	Dummy (B1, B2)	
Required load [g]	4.5	
Required load [N]	5850	
Minimum test duration [s]	5	
Result		
Test duration [s]	9.4	
Any signs of structural failure	No	
Slippery test OK	Yes	
Test results	POSITIVE	

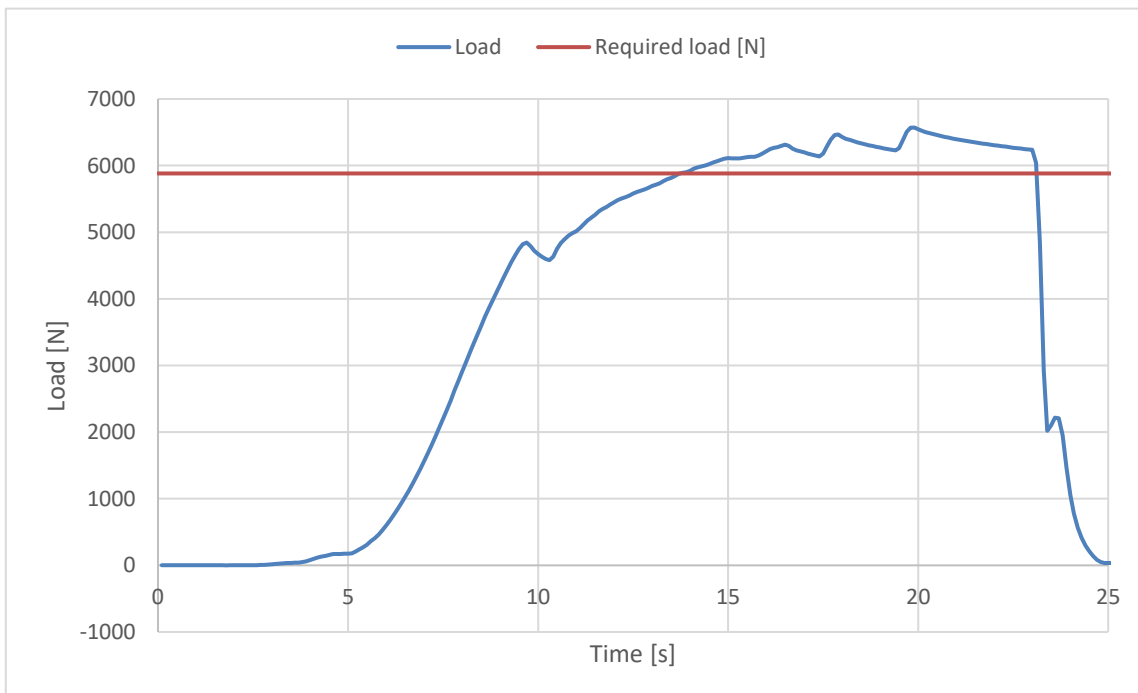

The validation of this test report is given by the signature of the test manager on the Inspection Certificate no 94.20

Inspection certificate number: **PH_289.2019**

model: **T_Line**

Harness Structural test

Test ID 03

Standard **EN 1651:2018**
 Reference in standard **5.5.1.1b**
 Test setup **Positive symmetric load**
 Attachment points **Both main riser attachment (3,4)**
 Anchor points **Dummy (B1, B2)**

Required load [g] **15**
 Required load [N] **19500**
 Minimum test duration [s] **5**

Result

Test duration [s] **8.1**
 Any signs of structural failure **No**
 Slippery test OK **Yes**
 Test results **POSITIVE**

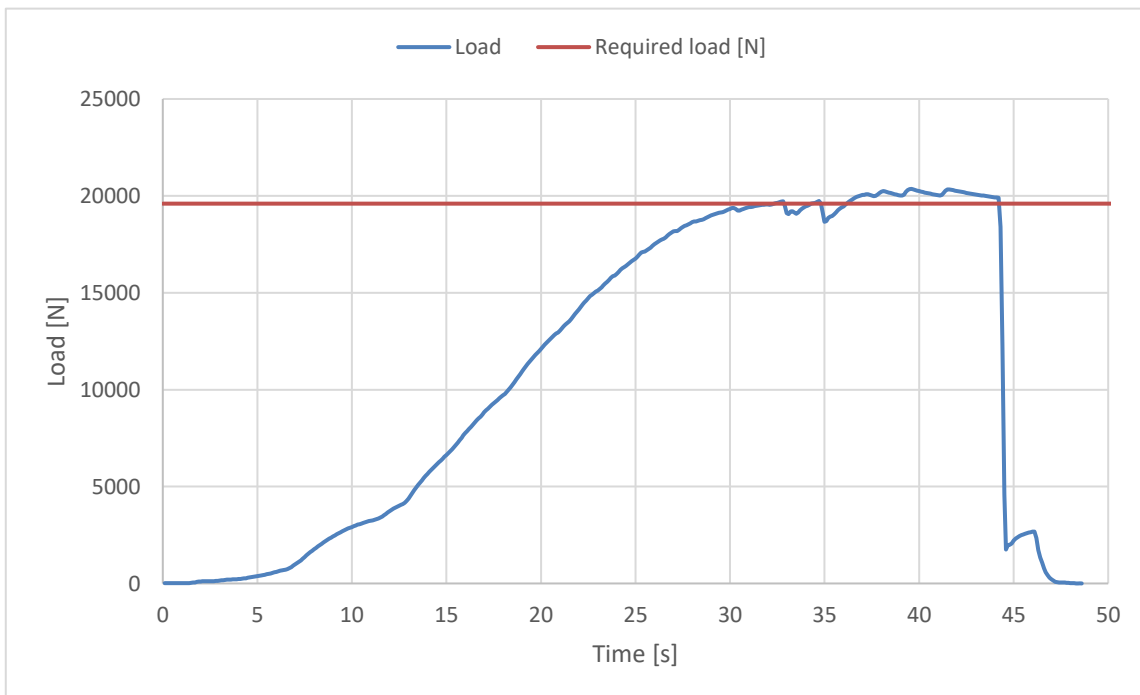
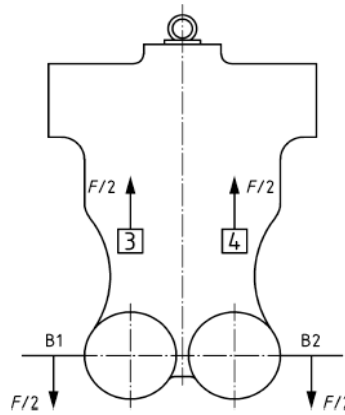

The validation of this test report is given by the signature of the test manager on the Inspection Certificate no 94.20

Inspection certificate number: **PH_289.2019**

model: **T_Line**

Harness Structural test

Test ID 05

Standard	EN 1651:2018
Reference in standard	5.5.1.2
Test setup	Positive asymmetric load
Attachment points	One riser attachment (3 or 4)
Anchor points	Dummy (C)
Required load [g]	6
Required load [N]	7800
Minimum test duration [s]	5
Result	
Test duration [s]	9
Any signs of structural failure	No
Test results	POSITIVE

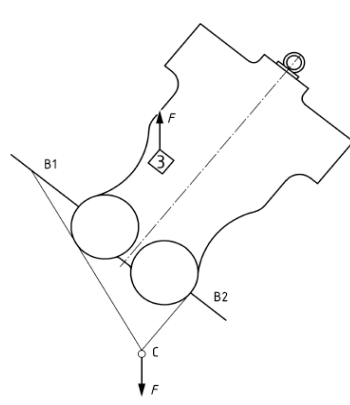
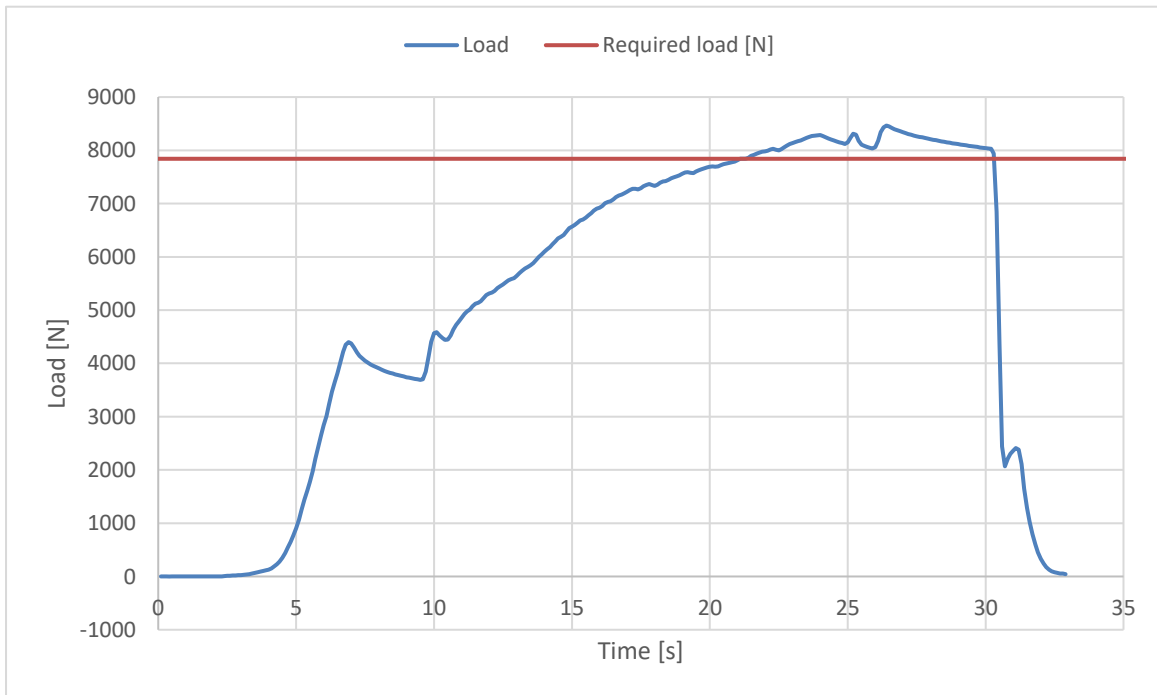
The validation of this test report is given by the signature of the test manager on the Inspection Certificate no 94.20

Inspection certificate number: **PH_289.2019**

model: **T_Line**

Harness Structural test

Test ID 14

Standard **EN 1651:2018**
 Reference in standard **5.5.1.5**
 Test setup **Negative symmetric load towing points**
 Attachment points **Both towing attachment (5,6)**
 Anchor points **Both main riser attachment (3,4)**

Required load [g] **5**
 Required load [N] **6500**
 Minimum test duration [s] **5**

Result

Test duration [s] **8.1**
 Any signs of structural failure **No**
 Test results **POSITIVE**

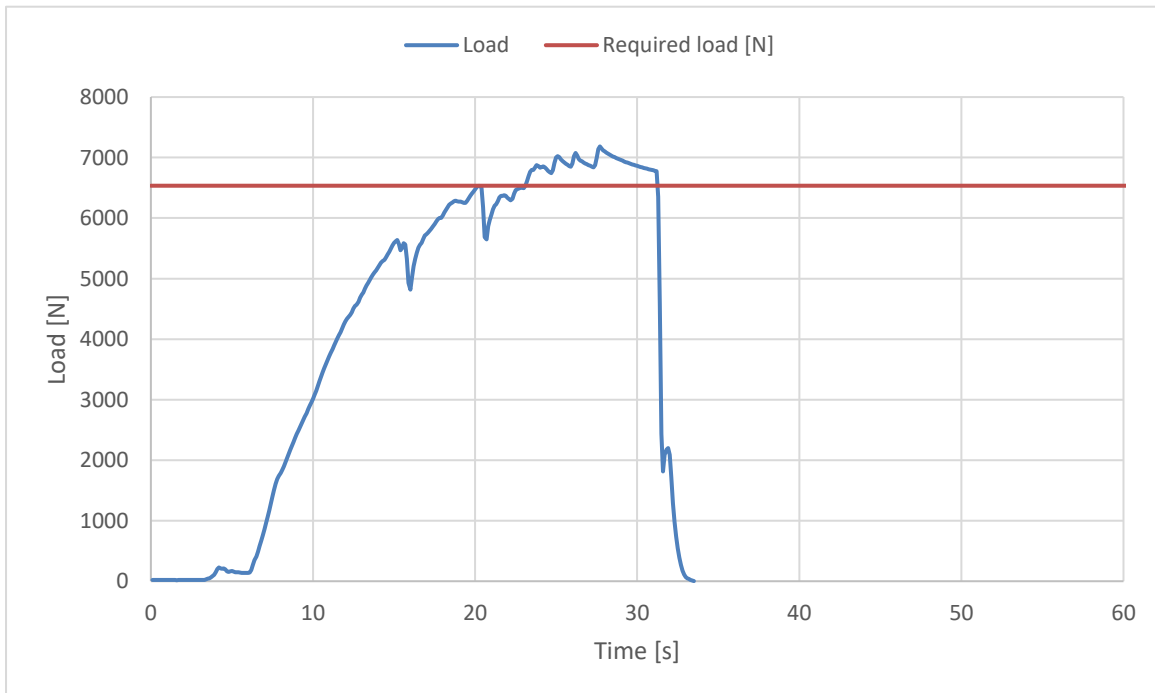
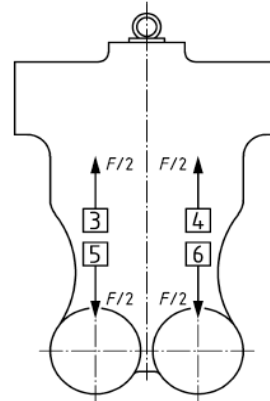

The validation of this test report is given by the signature of the test manager on the Inspection Certificate no 94.20

Inspection certificate number: **PH_289.2019**

model: **T_Line**

Harness Structural test

Test ID 06

Standard	EN 1651:2018
Reference in standard	5.5.1.6
Test setup	Negative symmetric load
Attachment points	Both main riser attachment (3,4)
Anchor points	Dummy (A)
Required load [g]	6
Required load [N]	7800
Minimum test duration [s]	5
Result	
Test duration [s]	8.7
Any signs of structural failure	No
Test results	POSITIVE

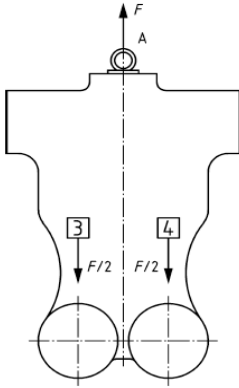
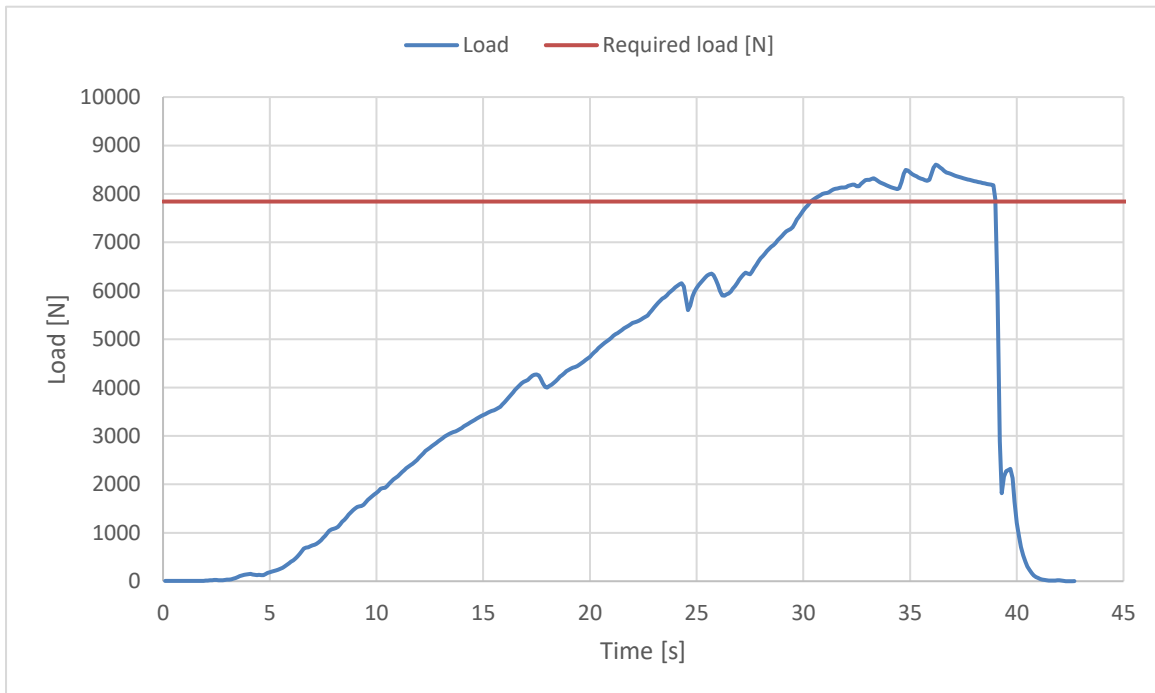
The validation of this test report is given by the signature of the test manager on the Inspection Certificate no 94.20

Inspection certificate number: **PH_289.2019**

model: **T_Line**

Harness Structural test

Test ID 11

Standard	EN 1651:2018
Reference in standard	5.5.1.8
Test setup	Connecting element for rescue
Attachment points	End point (emergency parachute)
Anchor points	Both attachment to harness
Required load [g]	n/a
Required load [N]	24000
Minimum test duration [s]	0.3
Type of connecting element	n/a
Result	
Test duration [s]	0
Any signs of structural failure	n/a
Test results	n/a

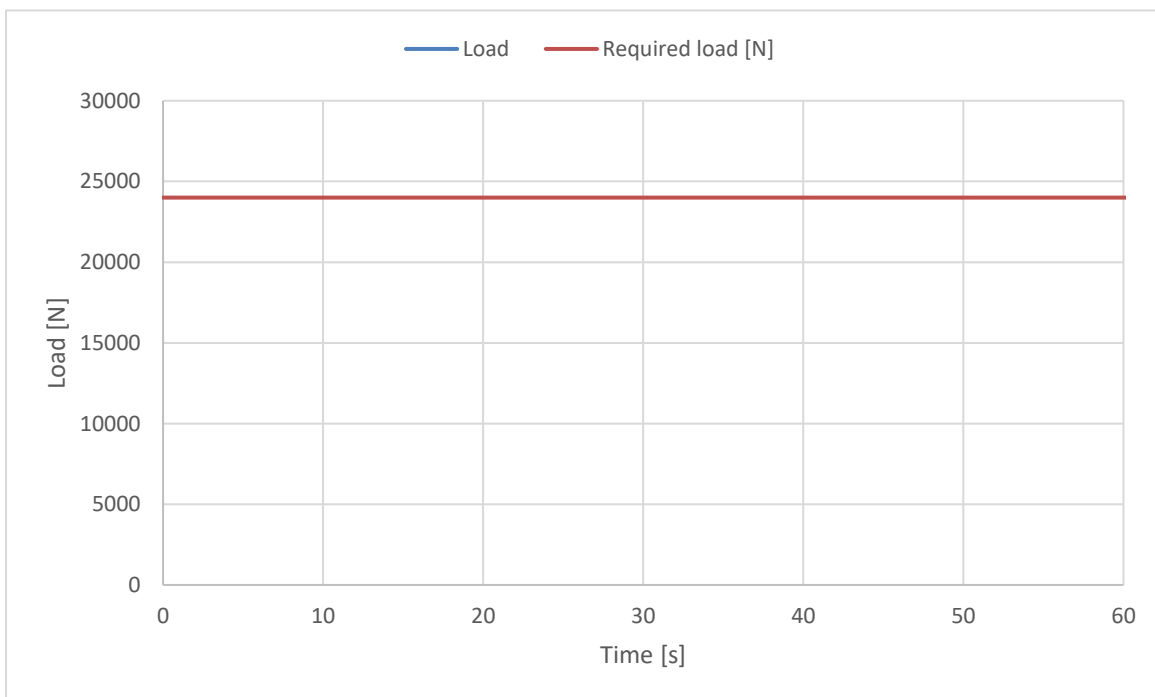

The validation of this test report is given by the signature of the test manager on the Inspection Certificate no 94.20