

Harness Structural test Report - LTF

Inspection certificate number: **PH_327.2021**

Manufacturer data:

Manufacturer name: **Niviuk Gliders**
 Representative: **Dominique Cizeau**
 Street: **C. Del Ter, 6-Nave D**
 Post code place: **17165 La Cellera de Ter Girona**
 Country: **Spain**

Sample data:

Name: **Hawk**
 Type: **ABS**
 Size: **L**
 Serial number: **Arrow L-V8**
 Impact pad type: ⁽¹⁾ **Foam**
 Clip-in weight [kg]: **120**

Date of test: **22.10.2020**

Atmosphere AGL:

| | |
|--------|--------------|
| [C°] | 20.7 |
| RH [%] | 48 |
| [hPa] | 973.2 |

Summary of Structural test

| Test id | - Ref. | Setup | Req. Load [g] | Req. Load [N] | Min. duration [s] | Result |
|---------|-----------|--------------------------------|---------------|---------------|-------------------|----------|
| 02 | ✓ 5.3.2.1 | Default flying position | 6 | 7200 | 10 | POSITIVE |
| 03 | ✓ 5.3.2.2 | Default flying position | 15 | 18000 | 5 | POSITIVE |
| 04 | ✓ 5.3.2.3 | Asymmetric, one riser | 6 | 7200 | 10 | POSITIVE |
| 07 | ✓ 5.3.2.6 | Asymmetric, negative | 4.5 | 5400 | 10 | POSITIVE |
| 09 | ✓ 5.3.2.4 | Rescue attachments | 15 | 18000 | 5 | POSITIVE |
| 13 | ✓ 5.3.2.7 | Flying position before landing | 15 | 18000 | 5 | POSITIVE |
| 14 | 5.3.2.5 | Towing | 5 | 6000 | 10 | n/a |

Rescue deployment test

| Test id | - LTF NfL II 91/09 | Setup | Min load [N] | Max. load [N] | Measured [N] | Result |
|---------|--------------------|-------------------------|--------------|---------------|--------------|----------|
| RRDT | ✓ 6.1.5 | Default flying position | 20 | 70 | 35.69 | POSITIVE |

Rescue Deployment Handle strength test

| Test id | - EN 12491 | Setup | Req. Load [N] | Min. duration [s] | Breaking strength [N] | Result |
|---------|------------|--------------------------|---------------|-------------------|-----------------------|----------|
| RRST | ✓ 5.3.2 | Two end points of handle | 700 | 10 | 1793.31 | POSITIVE |

| Manufacture | Instrument | Type no | S/N | Validity Calibration |
|-------------|--------------------|--------------|----------|----------------------|
| HBM | Load Sensor GE01 | 1-S9M/50KN-1 | 31314643 | 04.09.2023 |
| Burster | Sensor Burster | 8431-10000 | 1185483 | 04.09.2023 |
| JDC elec | Geos n°11 Skywatch | Geos n°11 | Unit11 | 18.06.2025 |

Air Turquoise SA, having thoroughly assessed the sample mentioned above, declare it was found conform with
 Airworthiness Requirements LTF NfL II 91/09 - EN12491:2015 5.3.2

The validation of this test report is given by the signature of the test manager on the Inspection Certificate no 94.20

⁽¹⁾ If Impact pad available, see test report no. 94.22 and inspection certificate no. 94.20

Calculated value in tests reports include the value minus the uncertainty (on safe side) / The uncertainty stated is the expanded uncertainty obtained by multiplying the standard uncertainty by the coverage factor k = 2. The value of the measurand lies within the assigned range of values with a probability of 95%.

This declaration must not be reproduced in part without the written permission of AIR TURQUOISE SA.

Inspection certificate number: **PH_327.2021**

model: **Hawk**

Harness Structural test

Test ID 02

| | |
|---------------------------------|---|
| Standard | LTF NfL II 91/09 |
| Reference | 5.3.2.1 |
| Test setup | Default flying position |
| Attachment points | Both main riser attachment (3,4) |
| Anchor points | Dummy (B1, B2) |
| Required load [g] | 6 |
| Required load [N] | 7200 |
| Minimum test duration [s] | 10 |
| Result | |
| Test duration [s] | 14.1 |
| Any signs of structural failure | No |
| Test results | POSITIVE |

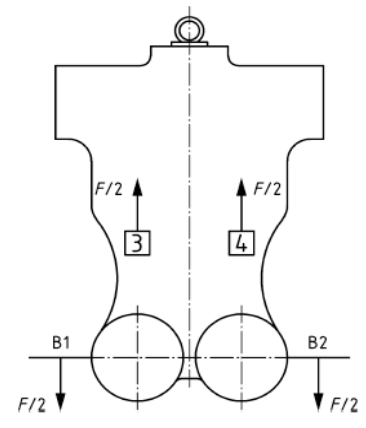
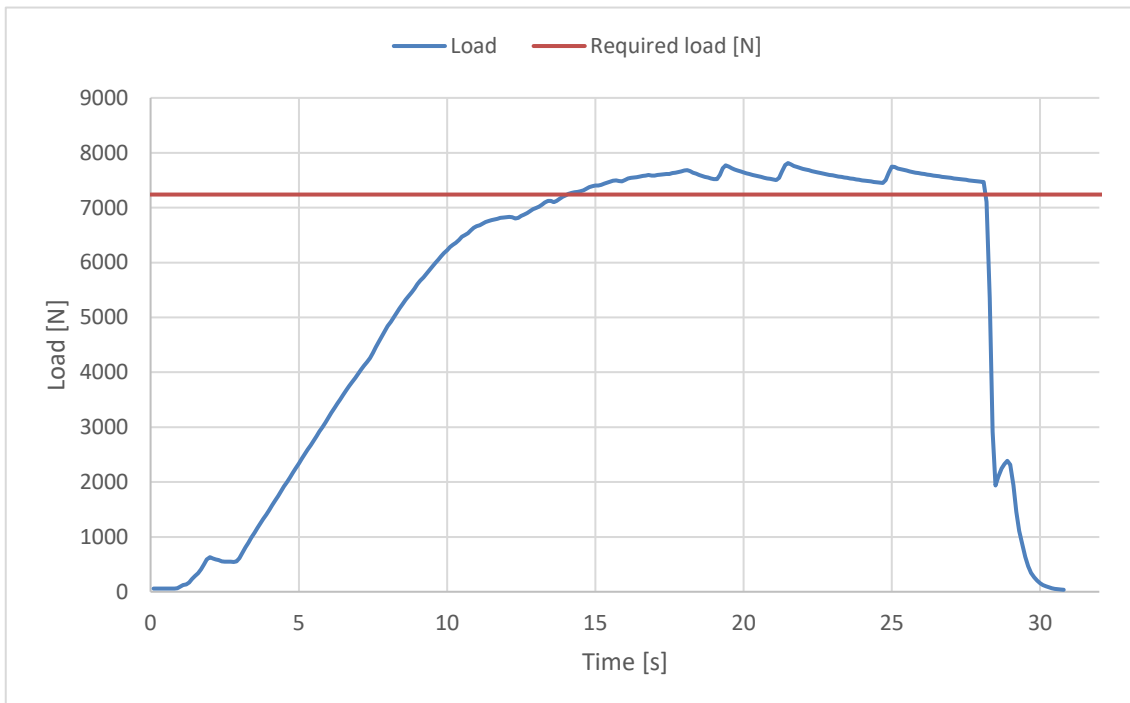
The validation of this test report is given by the signature of the test manager on the Inspection Certificate no 94.20

Inspection certificate number: **PH_327.2021**

model: **Hawk**

Harness Structural test

Test ID 03

Standard **LTF NfL II 91/09**
 Reference **5.3.2.2**
 Test setup **Default flying position**
 Attachment points **Both main riser attachment (3,4)**
 Anchor points **Dummy (B1, B2)**

Required load [g] **15**
 Required load [N] **18000**
 Minimum test duration [s] **5**

Result

Test duration [s] **7.5**
 Any signs of structural failure **No**
 Test results **POSITIVE**

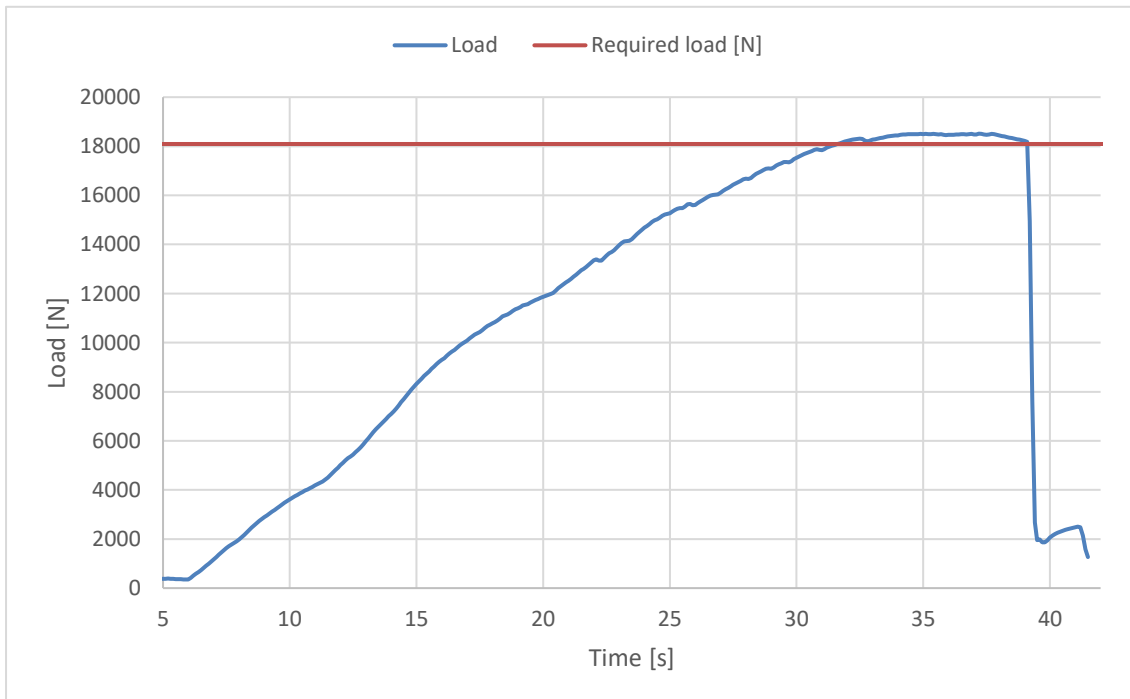
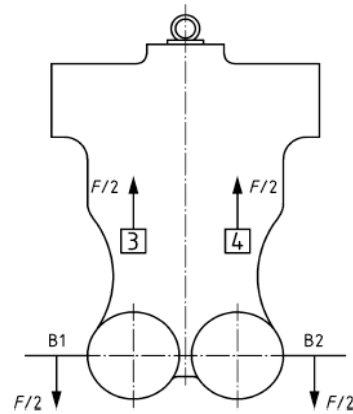

The validation of this test report is given by the signature of the test manager on the Inspection Certificate no 94.20

Inspection certificate number: **PH_327.2021**

model: **Hawk**

Harness Structural test

Test ID 04

| | |
|---------------------------------|--------------------------------------|
| Standard | LTF NfL II 91/09 |
| Reference | 5.3.2.3 |
| Test setup | Asymmetric, one riser |
| Attachment points | One main riser attachment (3) |
| Anchor points | Dummy (B1,B2) |
| Required load [g] | 6 |
| Required load [N] | 7200 |
| Minimum test duration [s] | 10 |
| Result | |
| Test duration [s] | 14.1 |
| Any signs of structural failure | No |
| Test results | POSITIVE |

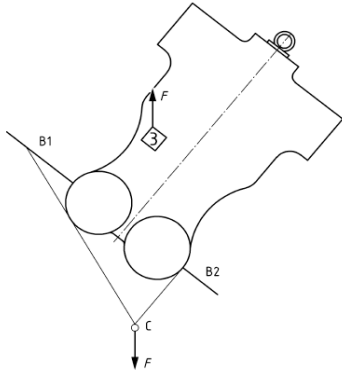
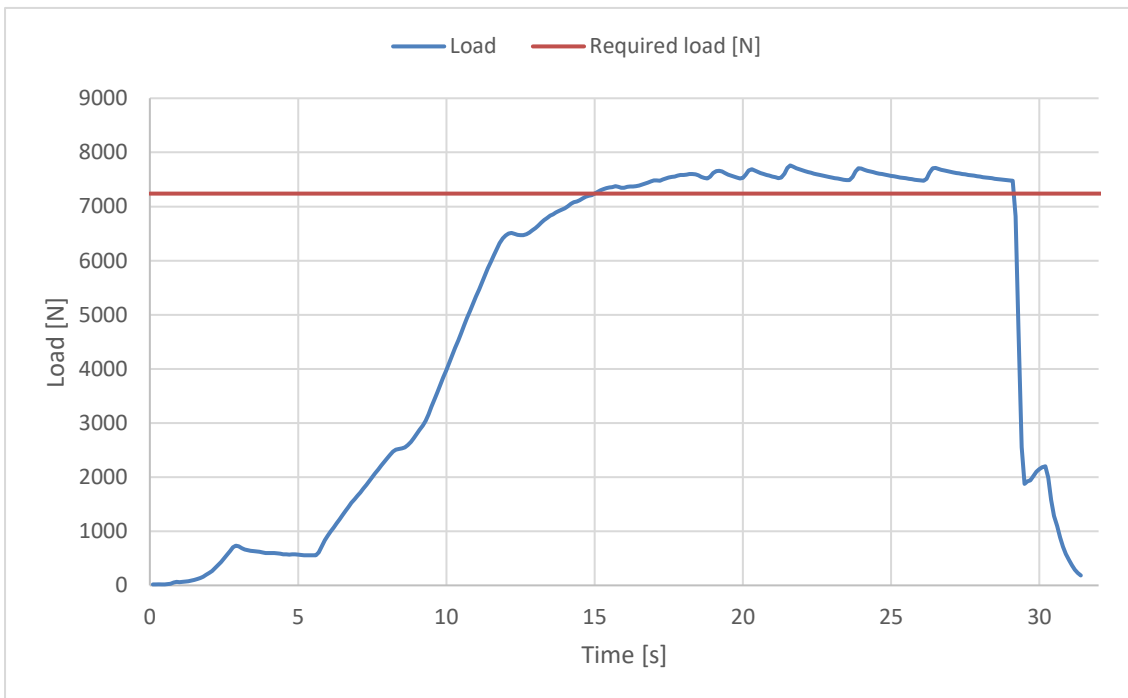
The validation of this test report is given by the signature of the test manager on the Inspection Certificate no 94.20

Inspection certificate number: **PH_327.2021**

model: **Hawk**

Harness Structural test

Test ID 07

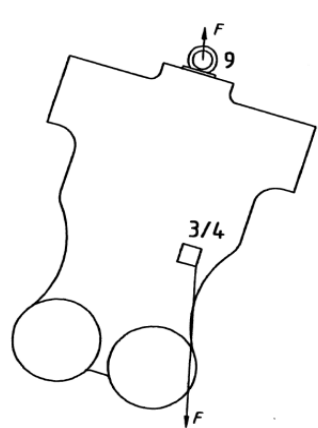
| | | |
|---------------------------------|---|--|
| Standard | LTF NfL II 91/09 |  |
| Reference | 5.3.2.6 | |
| Test setup | Asymmetric, negative | |
| Attachment points | One main riser attachment (3 or 4) downwards | |
| Anchor points | Dummy (9) | |
| Required load [g] | 4.5 | |
| Required load [N] | 5400 | |
| Minimum test duration [s] | 10 | |
| Result | | |
| Test duration [s] | 12.6 | |
| Any signs of structural failure | No | |
| Test results | POSITIVE | |

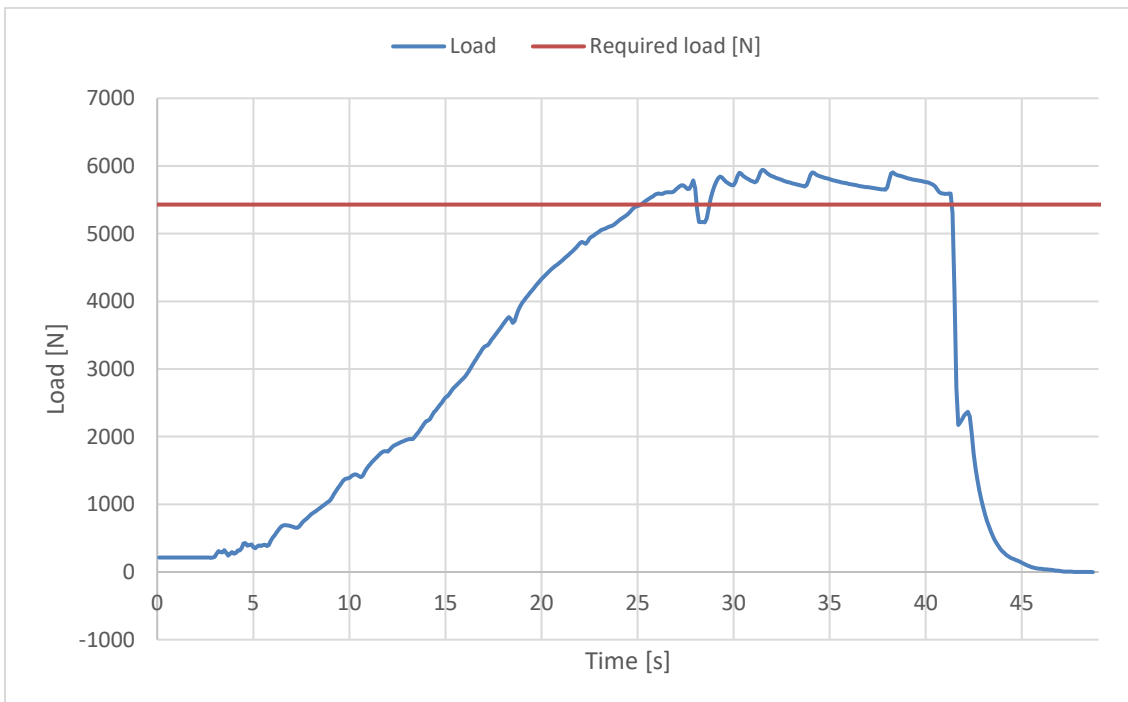

The validation of this test report is given by the signature of the test manager on the Inspection Certificate no 94.20

Inspection certificate number: **PH_327.2021**

model: **Hawk**

Harness Structural test

Test ID 09

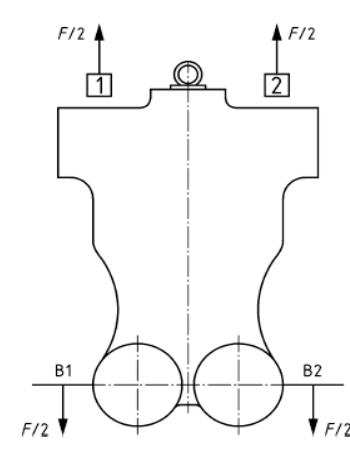
| | | |
|---------------------------------|--------------------------------------|--|
| Standard | LTF NfL II 91/09 |  |
| Reference | 5.3.2.4 | |
| Test setup | Rescue attachments | |
| Attachment points | Rescue riser attachment (1,2) | |
| Anchor points | Dummy (B1,B2) | |
| Required load [g] | 15 | |
| Required load [N] | 18000 | |
| Minimum test duration [s] | 5 | |
| Result | | |
| Test duration [s] | 10.4 | |
| Any signs of structural failure | No | |
| Test results | POSITIVE | |

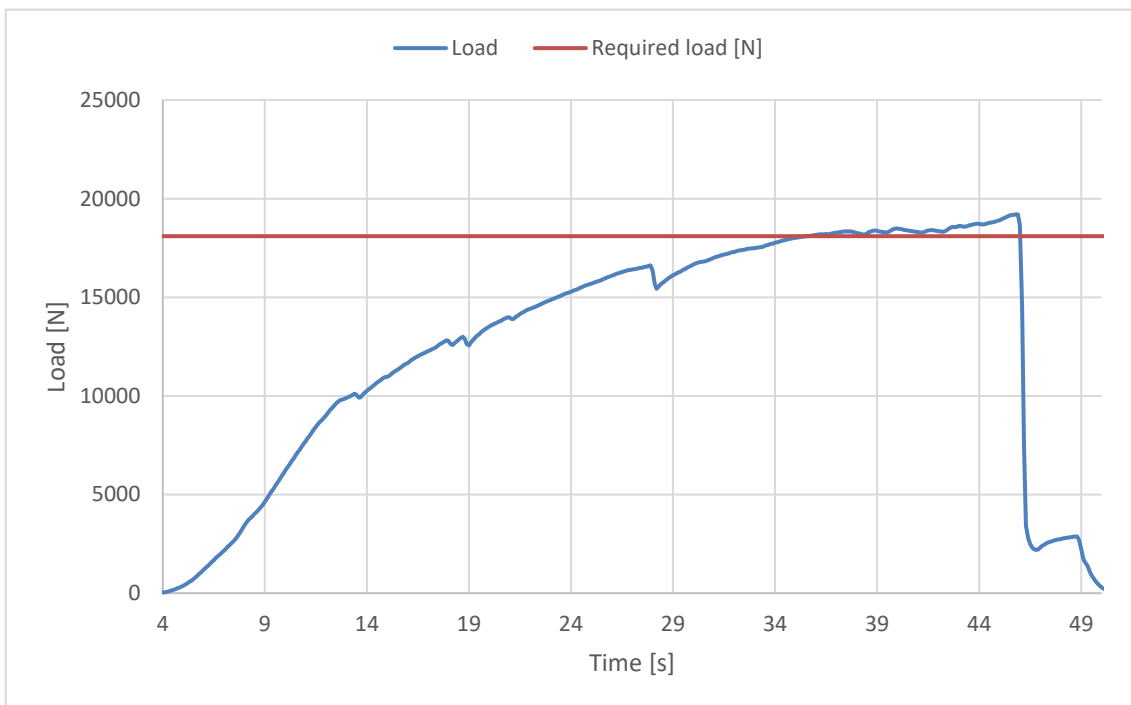

The validation of this test report is given by the signature of the test manager on the Inspection Certificate no 94.20

Inspection certificate number: **PH_327.2021**

model: **Hawk**

Harness Structural test

Test ID 13

Standard **LTF NfL II 91/09**
 Reference **5.3.2.7**
 Test setup **Flying position before landing**
 Attachment points **Both main riser attachment (3,4)**
 Anchor points **Dummy (7,8)**

Required load [g] **15**
 Required load [N] **18000**
 Minimum test duration [s] **5**

Result

Test duration [s] **9.2**
 Any signs of structural failure **No**
 Test results **POSITIVE**

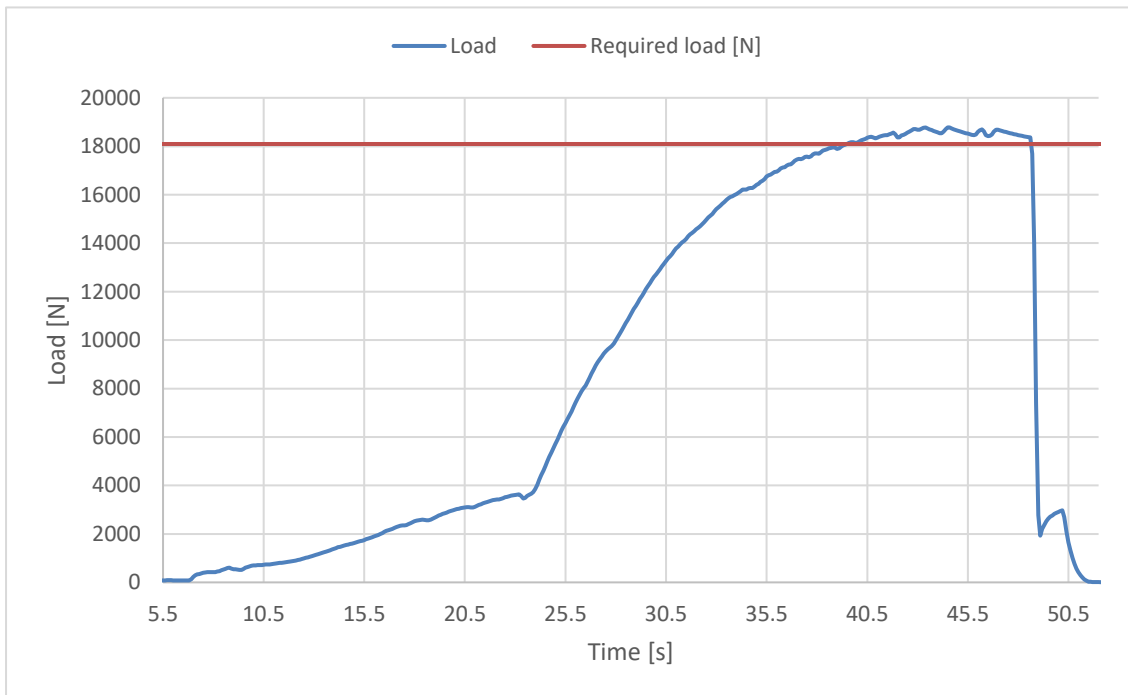
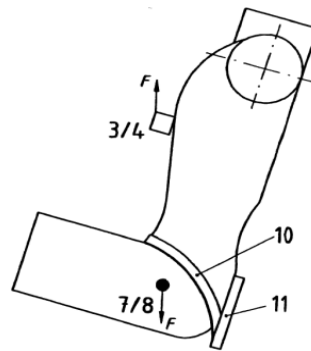

The validation of this test report is given by the signature of the test manager on the Inspection Certificate no 94.20

Inspection certificate number: **PH_327.2021**

model: **Hawk**

Rescue Deployment Test

Test ID RRDT

| | |
|---------------------------|--|
| Standard | LTF NfL II 91/09 |
| Reference | 6.1.5 |
| Test setup | Default flying position |
| Attachment points | Sensor connect to handle, and pull in opening direction The test is to simulate the load required to open the emergency parachute(1st action). |
| Min. Required load [N] | 20 |
| Max. Required load [N] | 70 |
| Result | |
| Load for first action [N] | 35.69 |
| Test results | POSITIVE |

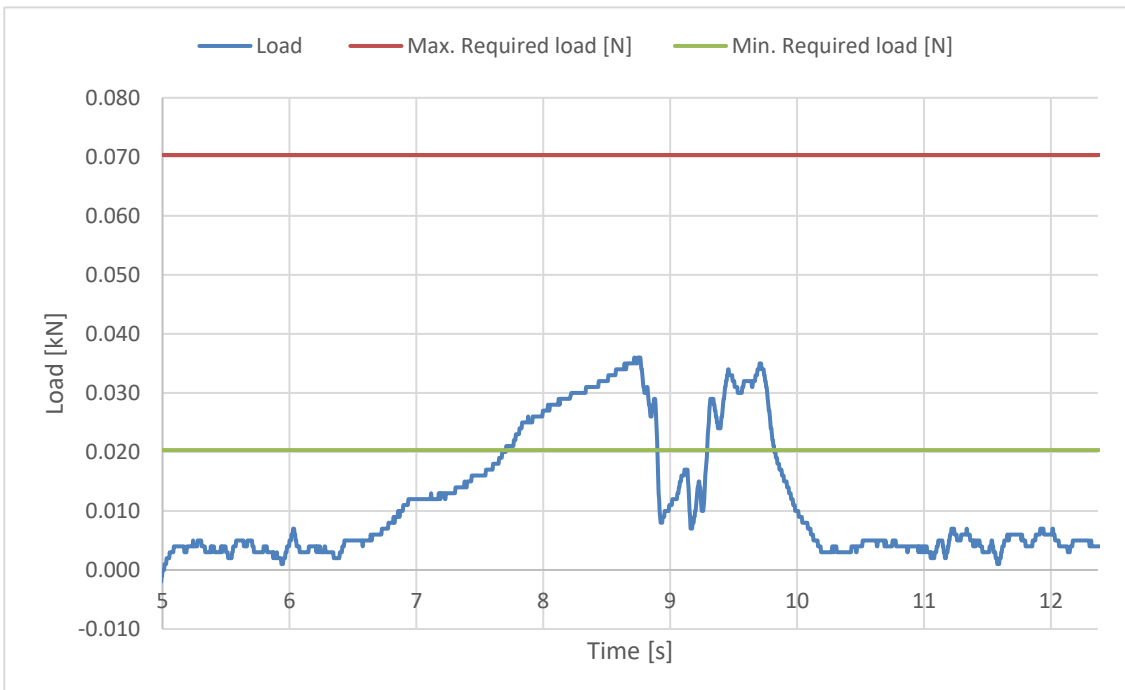

The validation of this test report is given by the signature of the test manager on the Inspection Certificate no 94.20

Inspection certificate number: **PH_327.2021**

model: **Hawk**

Rescue Deployment Handle strength test

Test ID RRST

| | |
|---------------------------|---|
| Standard | EN12491:2015 |
| Reference in standard | 5.3.2 |
| Test setup | Two end points of handle |
| Attachment points | Sensor connect to end of handle, pull on the other side |
| | The handle must support min 700 N for 10 s, after measure breaking strength |
| Min. Required load [N] | 700 |
| Minimum test duration [s] | 10 |
| Result | |
| Test duration [s]: | 20.8 |
| Breaking strength [N] | 1793.31 |
| Test results | POSITIVE |

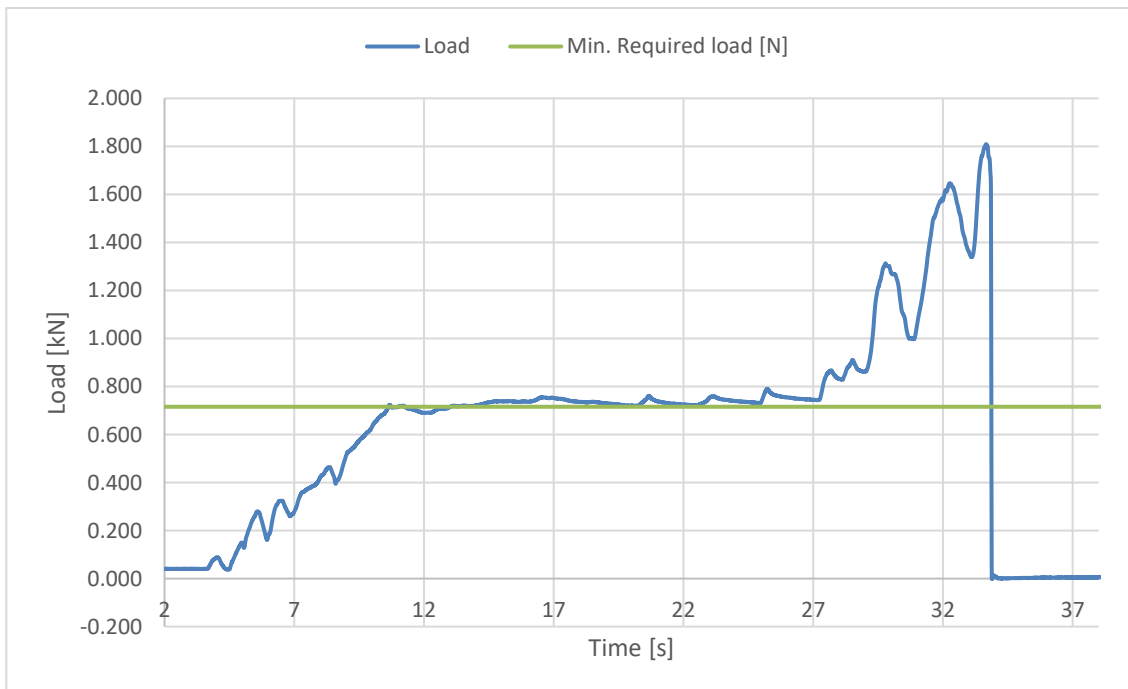

The validation of this test report is given by the signature of the test manager on the Inspection Certificate no 94.20