

Test report Kite security system

tested and certified after NF S52-503

Manufacturer Gin Kiteboarding
Adresse: Place du Village 67
 2518 Nods
 Switzerland

Cert.no. KS 002.2010
Model: Eskimo IV
Place/date: Villeneuve / 04.05.10

maximum weight 110 kg

Complete System

Test id.

- 1 **4.3.1.1 Verify installation of complete system; Main release, 2nd release and power system**
 In the report: Main release → chicken loop, 2nd release → Leash release
 Main release possible to mounting opposite, but still working. User manual is OK
- 2 **4.3.1.2.1 Test the complete system (new) at 15 daN**
 Main release ok
 2nd release ok
 Power adjustment ok
- 3 **4.3.1.2.2 Test the complete system (new) at 2 times the maximum weight 10 power-ups**
 ok

Security System

- 4 **4.3.1.3.2 Accessibility**
 at 15° ok
 at 45° ok
 Horizontally ok
- 5 **4.3.1.3.3 Releasing or accidental disconnection in load of 10 daN**
 It is verified that main release and 2nd release can not be activated unexpectedly
 ok
- 6 **4.3.1.3.4 Implementation with a load of 10 daN**
 at 15° ok
 at 45° ok
 Horizontally ok
- 7 **4.3.1.3.4.1 Single Action of both release system**
 Main release & 2nd release

	Main Release	2nd release
at 15°	ok	ok
at 45°	ok	ok
Horizontally	ok	ok

3.1.4.5.1 and 3.1.4.5.2
- 8 **4.3.1.3.4.2 Axis implementation**
 Verify that the ergonomics and kinematics of the axis of implementation
 Verify the systems are properly marked ok



- 9 **4.3.1.3.4.3 Area Implementation with a load of 10 daN**
 - to 15 ° from the vertical ok
 - to 45 ° from the vertical ok
 - to horizontal ok
- Verify that the implementation of the control has no significant risk to the rider.

Main Release System

- 10 **4.3.2.1.1 Measuring releasing time < 2s at maximum weight**
 - 15 ° from the vertical ok
 - horizontally ok
- Each test is repeated 5 times*

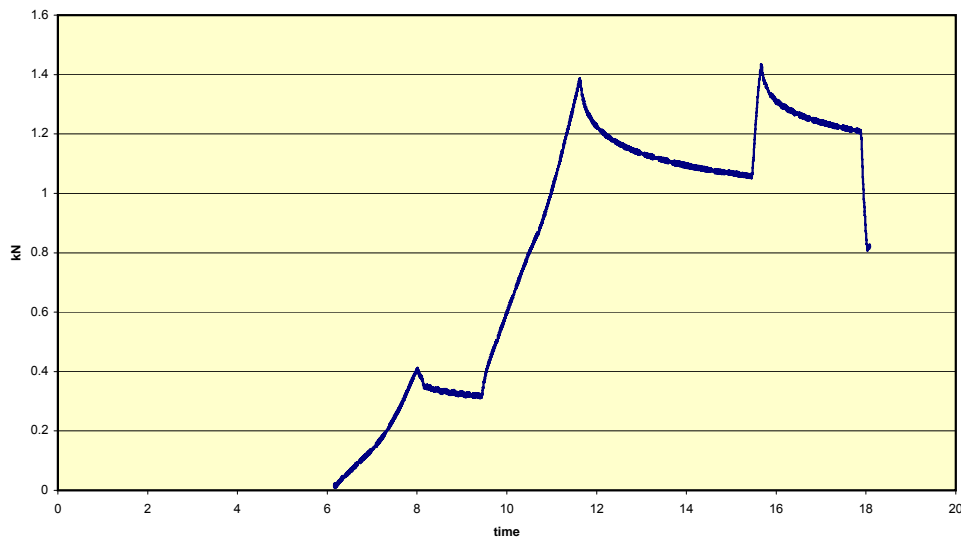

- 11 **4.3.2.1.2 Overload the System upto 3 times maximum weight**
 - tension gradually 3-6 seconds ok

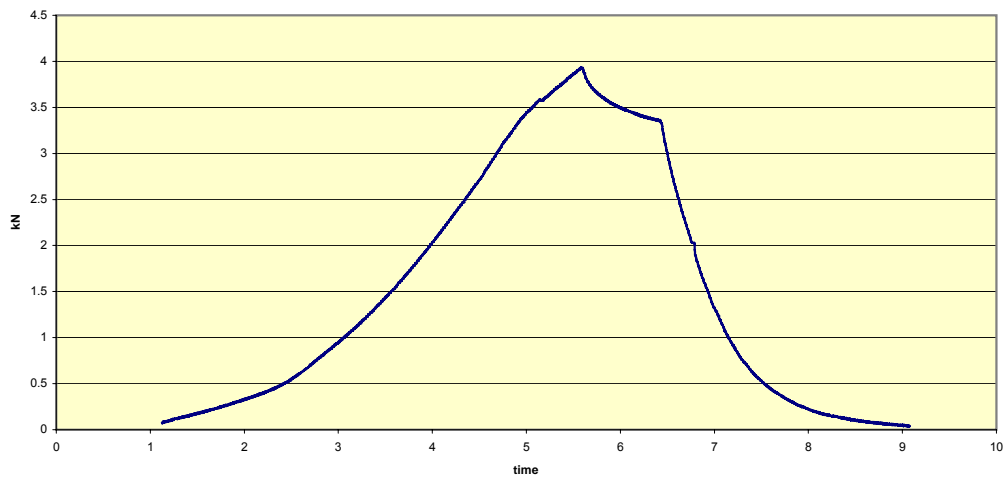

12 4.3.2.1.3 Deploy the security control, measuring of time and force

deploy force less than 10 daN and < 0.5s

2 times the maximum weight

1.5 times the maximum weight

the maximum weight

15 daN

9.8 kg
8 kg
4 kg
3 kg

220 kg

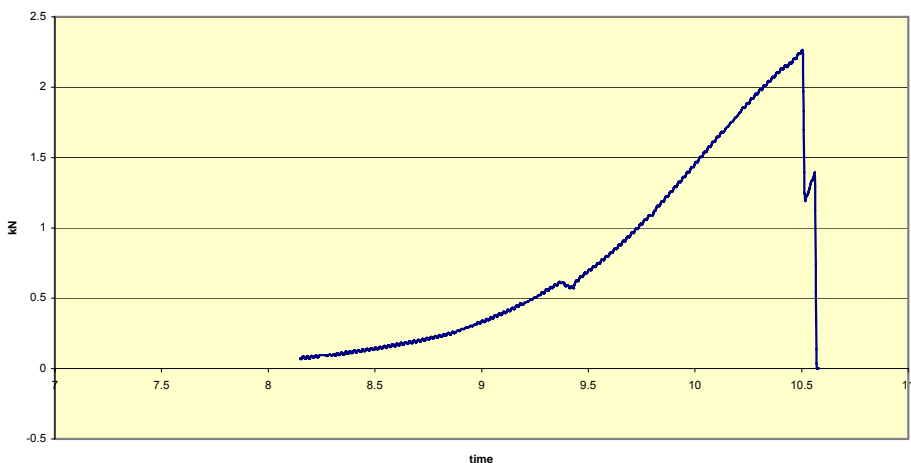

165 kg

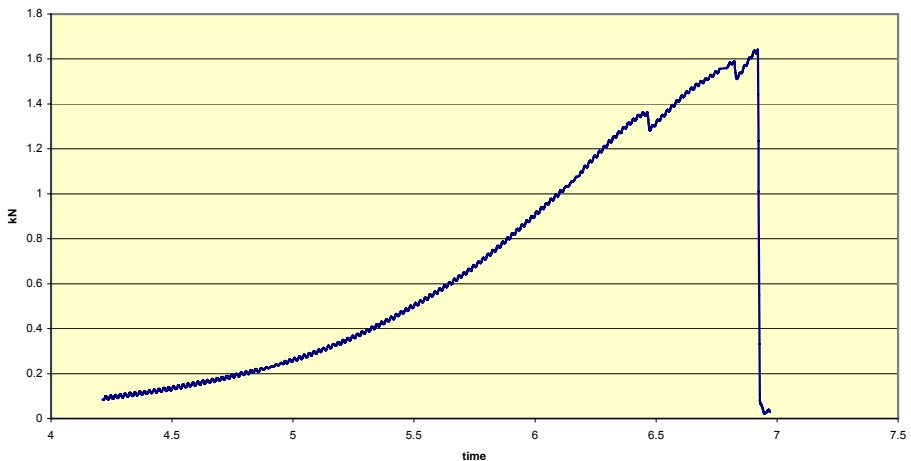



110 kg

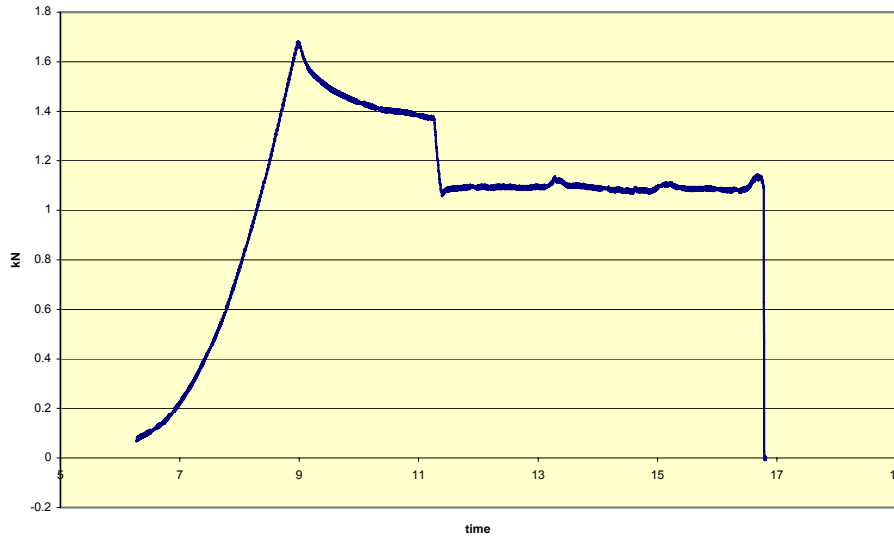

- 13** 4.3.2.1.3 / In a dry environment, test done without cleaning
 # 2 times the maximum weight 9.5 kg
 # 15 daN 3 kg
- 14** 4.3.2.1.3 / In wet environment, test done without cleaning, drying
 # 2 times the maximum weight 7.0 kg
 # 15 daN 0.7 kg
- 15** 4.3.2.1.3 / In cold environment, test done without drying
 # 2 times the maximum weight 9.5 kg
 # 15 daN 2 kg

2nd Release System

16 4.3.2.2.3 Deploy the security control, measuring of time and force

deploy force less than 10 daN and < 0.5s

1.5 times the maximum weight

the maximum weight

15 daN

9.8 kg
9.5 kg
2.5 kg

165 kg

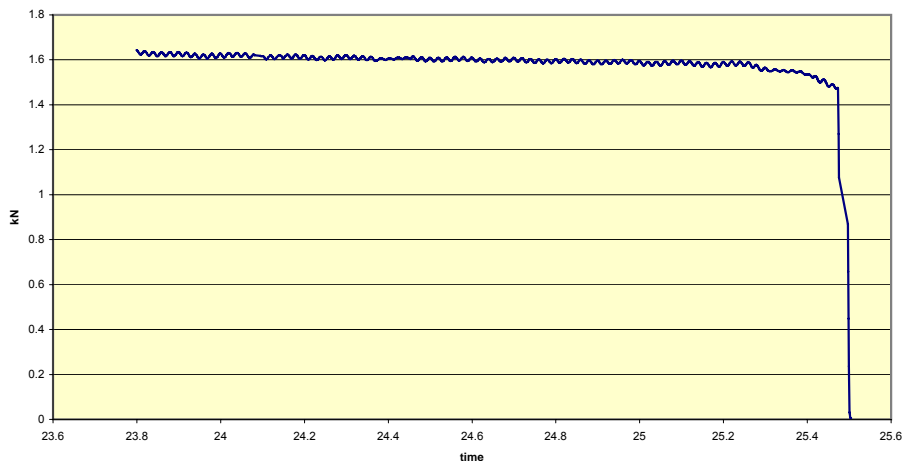

110 kg

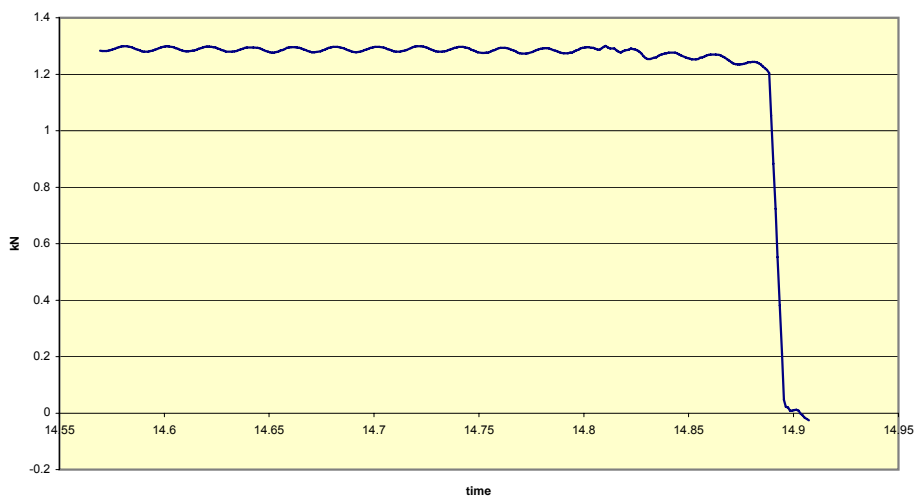



15 daN

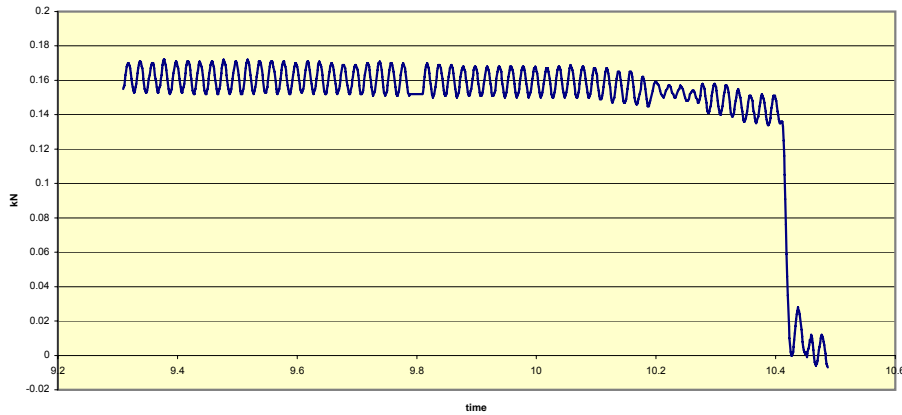

- 17** 4.3.2.2.3 / In a dry environment, test done without cleaning
 # 1.5 times the maximum weight 9.5 kg
 # 15 daN 2.5 kg

- 18** 4.3.2.2.3 / In wet environment, test done without cleaning, drying
 # 1.5 times the maximum weight 9 kg
 # 15 daN 2.5 kg

- 19** 4.3.2.2.3 / In cold environment, test done without drying
 # 1.5 times the maximum weight 7.3 kg
 # 15 daN 0.4 kg



Information

Environments physicochemical**13&17 4.3.1.3.5.1 In a dry environment**

The test specimen is mixed with dry sand for 10 s in the sand tray.

14&18 4.3.1.3.5.2 In wet environment

The test specimen is immersed in a bath of salt water at 10% and sanded to 75% of its volume. It is mixed for 10 s.

15&19 System is placed for two hours at -18 degrees celcius.

The material is wetted by spraying water before placed in cold environment

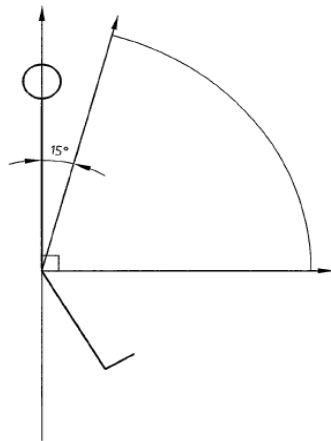

Figure 1 — Exemple de situations considérées comme prévisibles d'utilisation du système de sécurité

Figure 1: Example situations considered foreseeable use of the security system